

NAUTILUS HD

5/RED

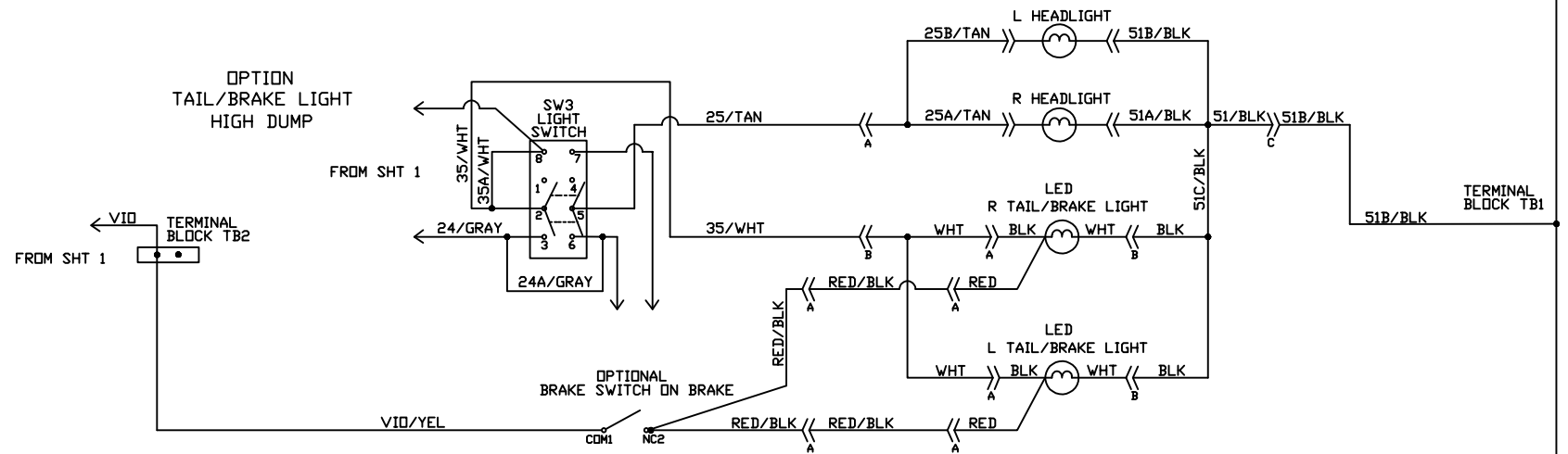
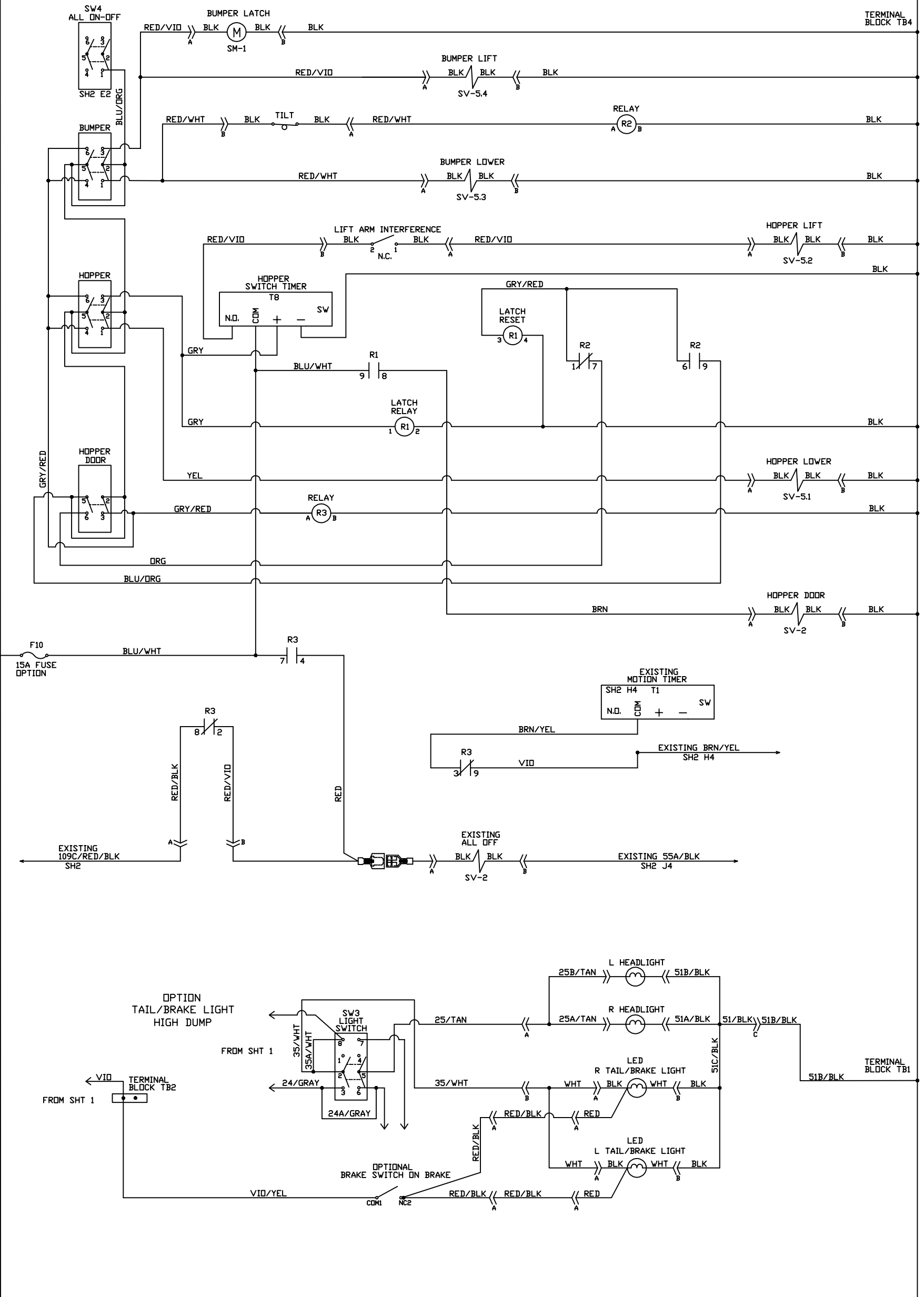

<p>CONFIDENTIAL</p> <p>THIS DRAWING AND ALL INFORMATION CONTAINED THEREIN ARE THE EXCLUSIVE PROPERTY OF MINUTEMAN INTERNATIONAL, INC. THIS DRAWING IS NOT TO BE COPIED OR OTHERWISE REPRODUCED WITHOUT EXPRESSED WRITTEN PERMISSION OF MINUTEMAN INTERNATIONAL, INC. IN ADDITION, THIS DRAWING MUST BE RETURNED UPON REQUEST. FURTHER, ALL INFORMATION CONTAINED HEREIN MUST BE MAINTAINED CONFIDENTIAL.</p>									
TITLE								SCALE	
NAUTILUS ELECTRICAL SCHEMATIC								NTS	
MATERIAL				FINISH					
N/A				N/A					
TOLERANCES (UNLESS OTHERWISE SPECIFIED)									
0-1" ± 1/16		.000 ± .005		SIZE		DRAWN BY		DATE	
>1-12" ± 1/4"		.00 ± .010		B		KHH		08/03/15	
<12" ± 1/2"		ANGLES ± 30'		CHECKED BY		JWP		DATE	
								08/03/15	
				14N845 U.S. ROUTE 20 PINGREE GROVE, IL 60140		P.N. 748992-1		REV J	
SHEET		4 OF 6							

REV	E.C.N.	DATE	CHANGE	BY	CHK BY
J	151969	02/02/22	ADD CONSTANT SOLUTION FLOW OPTIONS CHANGE F5 FUSE TO 20 AMPS, DELETE 106A	KHH	KHH
H	151293	04/09/20	UPDATED MURPHY SWITCH	KHH	KHH
G	150567	02/06/19	ADDED SIDE BROOM MIST OPTION	KHH	KHH
F	150447	10/18/18	ADD BRAKE LIGHTS	KHH	KHH